

DESCRIPTION

The TP-M15D Explosion-Proof Speaker provides added safety as to electrical operations, mechanical construction and temperature so as to prevent electrical equipment which do not generate sparks or heat that can ignite an explosive atmosphere under the condition of normal use from generating such sparks and heat.

SPECIFICATIONS

Rated Input	15 W
Rated Impedance	670 Ω (15 W), 1 kΩ (10 W), 2 kΩ (5 W)
Frequency Response	350 Hz - 4.5 kHz
Sensitivity	104 dB (1 W, 1 m)
Category	eG4 (Increased safety explosion-proof)
Standard Environmental Condition	Temperature: -20 °C to +40 °C Elevation: 1 km or less Relative humidity: 45 % to 85 % Others: Dust, corrosive gas or vibration which requires special considerations to be provided in the explosion-proof facility must not exist.
Finish	Horn: Ivory Others: Dark brown Bracket materials: Surface zinc treated steel plate (SECC, t3.2)
Dimensions	∅242 × 368 (D) mm
Weight	4.3 kg

Installation Locations

- ※ Locations where flammable gas and vapor of flammable liquid are mixed together under the abnormal condition, creating an atmosphere close to the threshold of explosion.
- ※ The TP-M15D cannot be used in locations that can periodically create an explosive atmosphere when used or operated normally.

[Poor Installation Location Examples]

- (1) Locations where vessels are damaged due to corrosion or deterioration, causing explosive gas to escape.
- (2) Locations which emit explosive gas due to malfunctions, or high temperature or high pressure as a result of irregular reaction.
- (3) Locations which can create an explosive atmosphere when the ventilation device fails and explosive gas stays.
- (4) Peripheral areas of or rooms adjacent to locations which can create an explosive atmosphere in a normal state and the explosive gas rarely enters such areas or rooms.

APPEARANCE

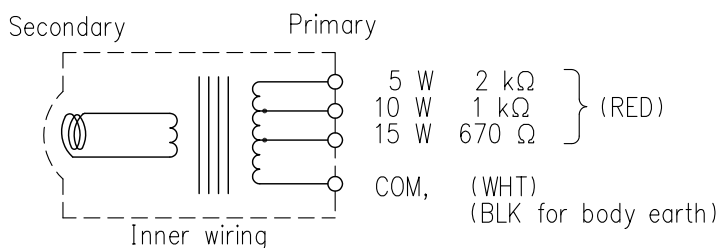
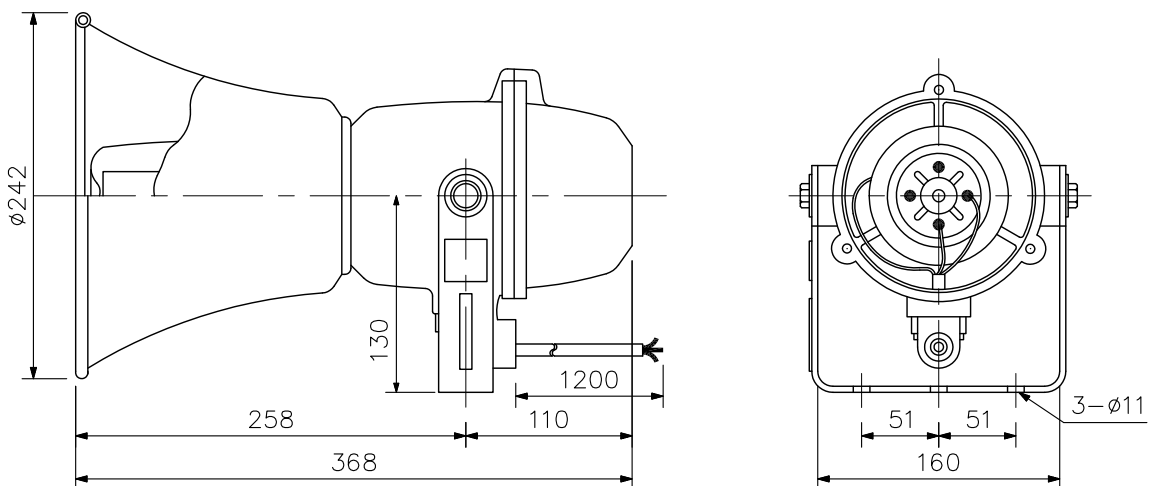

UNIT: mm SCALE: 1/5